

THIS DRAWING IS UNPUBLISHED. RELEASED FOR PUBLICATION
 (C) COPYRIGHT 19 BY AMP INCORPORATED. ALL RIGHTS RESERVED.

LOC		DIST		REVISIONS			
P	LTR	DESCRIPTION	DATE	DWN	APVD		
AF	50	J	REDRAWN PER OG1A-0030-98	3/4/98	JR	JG	

- 1 CONTINUOUS STRIP ON REELS
- 2 SEE DRAWING CP80-8238 FOR SUGGESTED CERAMIC DIMENSIONS.
- 3 EARS MAY BE CUT-OFF USING SPECIAL APPLICATOR AND SHEAR TOOLING AT OPTION OF CUSTOMER.

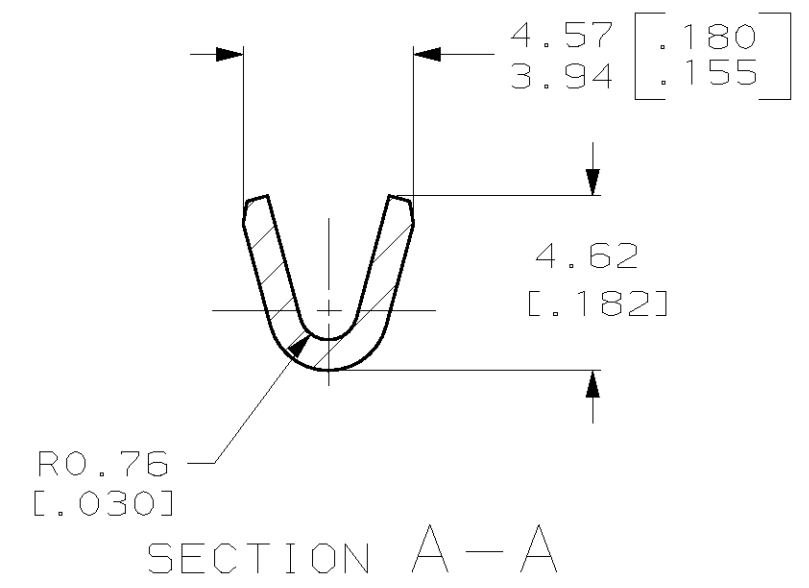
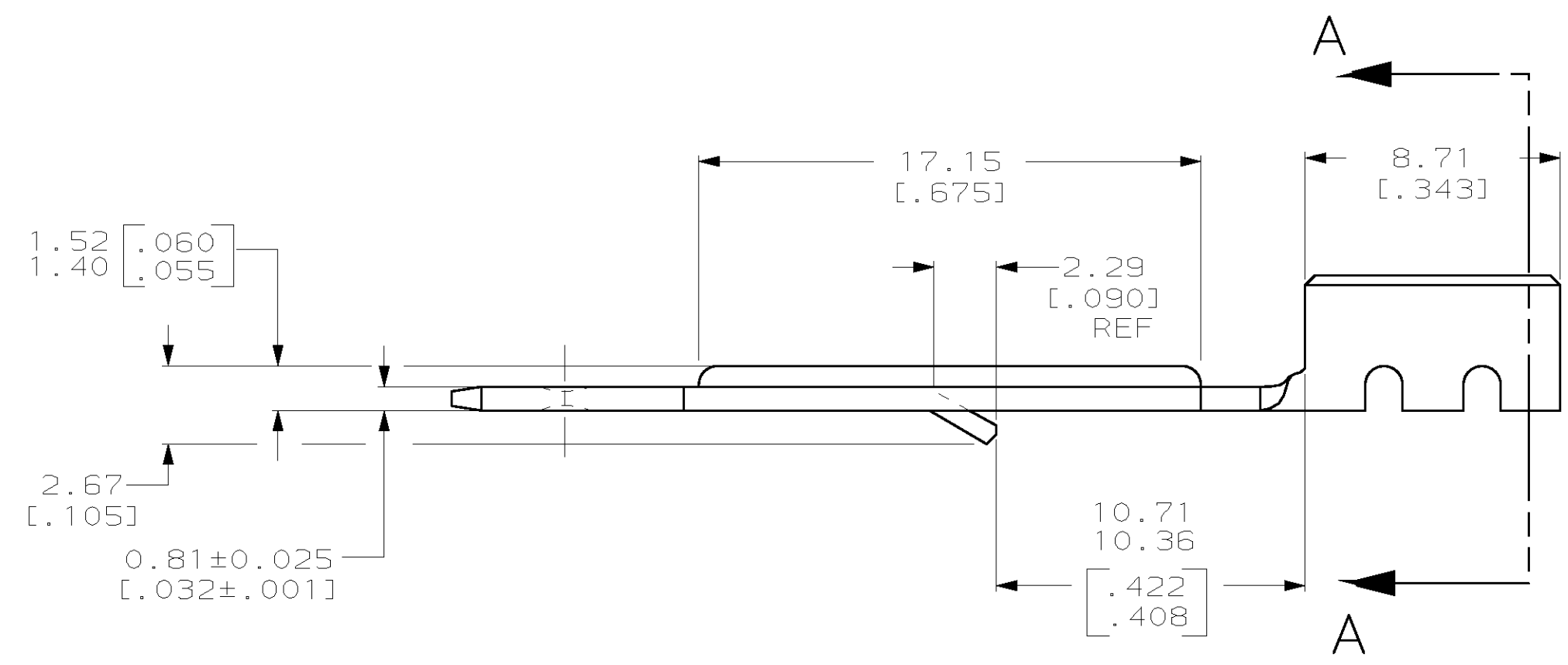
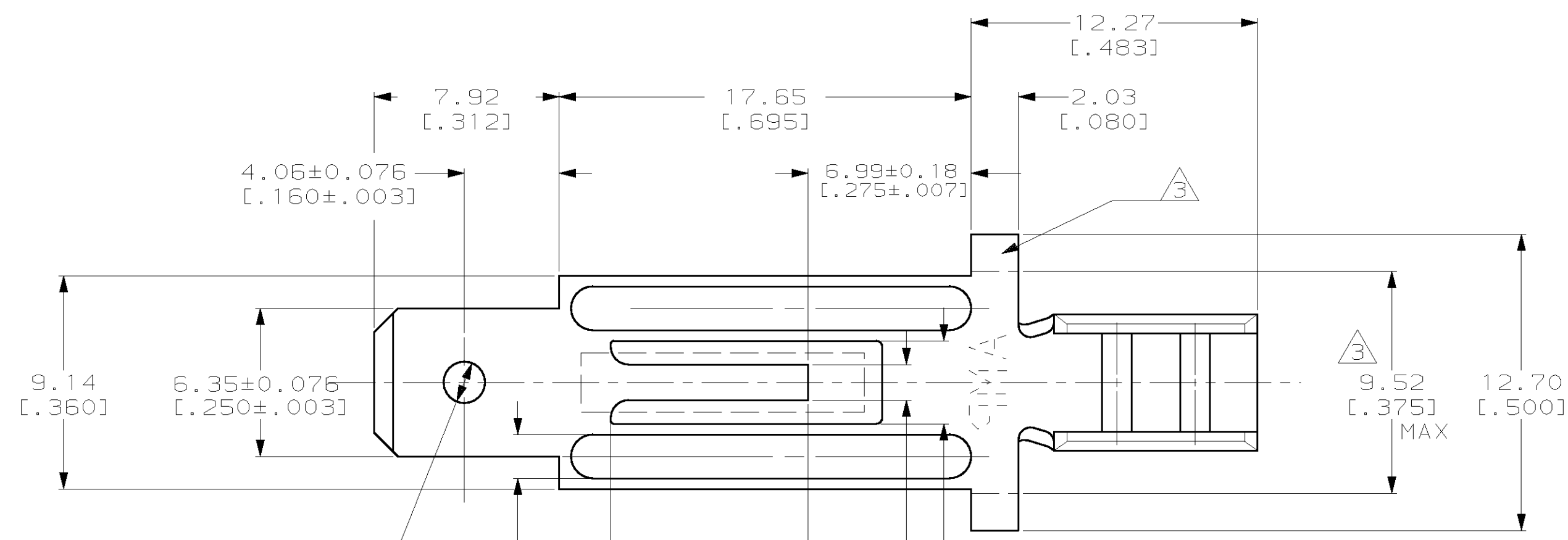

63104-1
PART NO.

THIS DRAWING IS A CONTROLLED DOCUMENT.		DWN	JR RUTH	3/4/98	AMP Incorporated Harrisburg, PA 17105-3608
DIMENSIONS: MM (INCHES)		CHK	MS FEHER	3/4/98	
TOLERANCES UNLESS OTHERWISE SPECIFIED: 0 PLC ±- 1 PLC ±- 2 PLC ±0.3B [.015] 3 PLC ±- 4 PLC ±- ANGLES ±-		APVD	J GILLESPIE	3/4/98	
MATERIAL: T2 C.R. STEEL		FINISH	NICKEL		
PRODUCT SPEC		NAME		TAB, FASTON™, HIGH-TEMP, .250 SERIES, FOR NI-CHROME WIRE	
APPLICATION SPEC		SIZE		A2 00779 C- 63104	
WEIGHT		SCALE		5:1	
CUSTOMER DRAWING		SHEET		1 OF 1	
		REV		J	